

F202 & F302 Ice Machine Plumbing and Dimensions Information

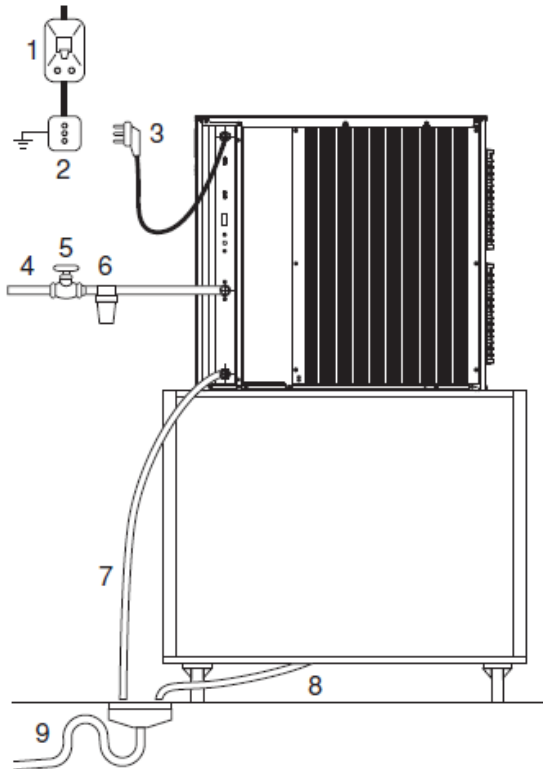

Air Cooled



Index

1. Mains Trip
2. Mains Socket
3. Unit Mains Plug
4. Water Inlet
5. Shut-off Valve
6. Water Filter (If applicable)
7. Waste Water Outlet Line
8. Bin Waste Outlet Line
9. Water Drain (Open Vented)

Dimensions

Water Drain (20mm \varnothing) to Units base – 43.5mm
Water Inlet ($\frac{3}{4}$ ") to Units base – 263.5mm
Mains Plug/Lead connection to unit to Units base – 508.5mm

Water Drain to Floor (Including SB150 Bin) –1103.5 mm
Water Inlet to Floor (Including SB150 Bin) – 1323.5mm
Water Drain to Floor (Including SB210 Bin) – 1023.5mm
Water Inlet to Floor (Including SB210 Bin) – 1243.5mm

All outlets are positioned 75mm from the inner edge of the machine at the rear of the unit (opposite side of the air filter).

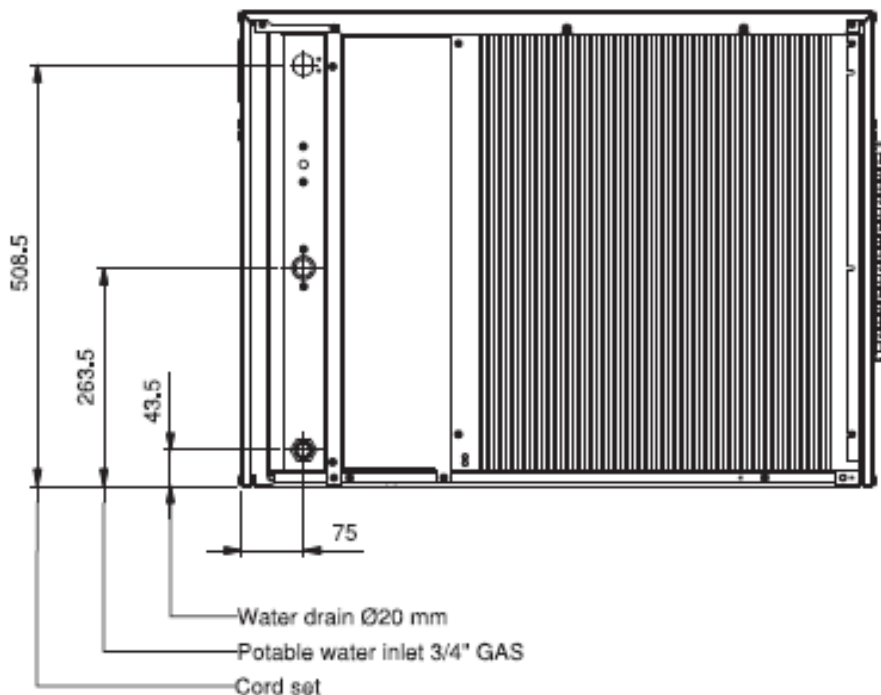

Unit & Individual Bin Dimensions

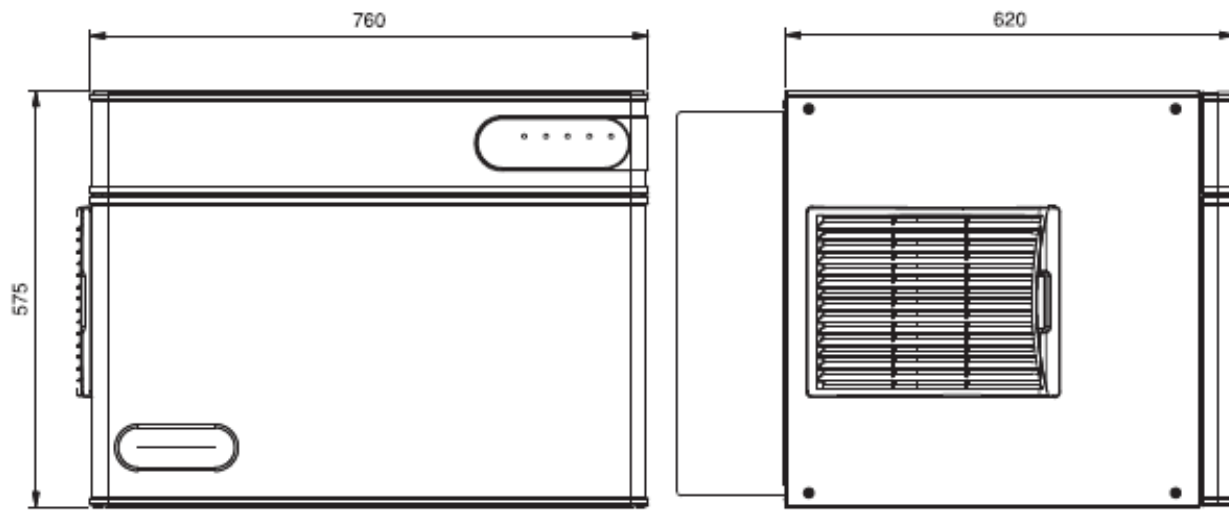

Rear of Unit

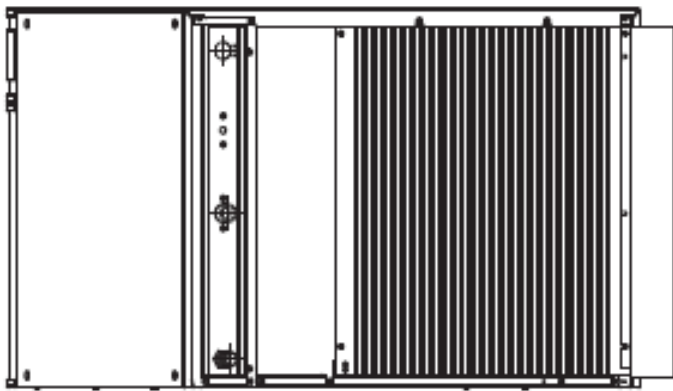

SB150

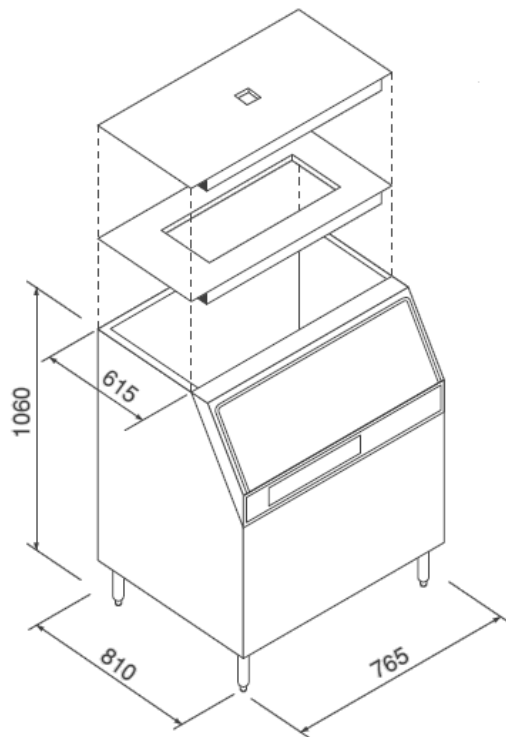

SB210

