

## DISPOSAL REQUIREMENTS

If not disposed of properly all refrigerators have components that can be harmful to the environment. All old refrigerators must be disposed of by appropriately registered and licensed waste contractors, and in accordance with UK laws and regulations.

## ENVIRONMENTAL MANAGEMENT POLICY.

### PRODUCT SUPPORT AND INSTALLATION CONTRACTORS

Foster Refrigerator recognises that its activities, products and services can have an adverse impact upon the environment. The organisation is committed to implementing systems and controls to manage, reduce and eliminate its adverse environmental impacts wherever possible, and has formulated an Environmental Policy outlining our core aims. A copy of the Environmental Policy is available to all contractors and suppliers upon request.

The organisation is committed to working with suppliers and contractors where their activities have the potential to impact upon the environment. To achieve the aims stated in the Environmental Policy we require that all suppliers and contractors operate in compliance with the law and are committed to best practice in environmental management.

Product Support and Installation contractors are required to:

1. Ensure that wherever possible waste is removed from the client's site, where arrangements are in place all waste should be returned to Foster Refrigerator's premises. In certain circumstances waste may be disposed of on the clients site; if permission is given, if the client has arrangements in place for the type of waste.
2. If arranging for the disposal of your waste, handle, store and dispose of it in such a way as to prevent its escape into the environment, harm to human health, and to ensure the compliance with the environmental law. Guidance is available from the Environment Agency on how to comply with the waste management 'duty of care'.
3. The following waste must be stored of separately from other wastes, as they are hazardous to the environment: refrigerants, polyurethane foam, oils.
4. When arranging for disposal of waste, ensure a waste transfer note or consignment note is completed as appropriate. Ensure that all waste is correctly described on the waste note and include the appropriate six-digit code from the European Waste Catalogue. Your waste contractor or Foster can provide further information if necessary.
5. Ensure that all waste is removed by a registered waste carrier, a carrier in possession of a waste management licence, or a carrier holding an appropriate exemption. Ensure the person receiving the waste at its ultimate destination is in receipt of a waste management licence or valid exemption.
6. Handle and store refrigerants in such a way as to prevent their emission to atmosphere, and ensure they are disposed of safely and in accordance with environmental law.
7. Make arrangements to ensure all staff who handle refrigerants do so at a level of competence consistent with the City Guilds 2078 Handling Refrigerants qualification or equivalent qualification.

## CONTENTS

	Page
Table of Contents	2
Duet Package Refrigeration System	2
Duet Specifications	3
Cooler Specifications	4
Condensing Unit Technical Data	5
FKS Cooler Dimensions	6
FTG Cooler Dimensions	7
Liquid and Suction Line Pipe Size	7
Control Panel	8
Microprocessor Controls - Duet HV, GP Series	8
Thermostat Function	8
Display	8
Microprocessor Controls - Duet C, F, M, and L Series	9
Thermostat Function	9
Display	10
Controller Parameter Settings	10-11
Electrical System Description	11
Duet Package Wiring Schematic	12
Duet Installation Guidelines	13

# Cooler Specification

## FTG Range

Model	Capacity 8°K TD		Connections		FAN AND MOTOR SPECIFICATION									Electric Defrost		
	R404A/R507A	R134a	Inlet	Outlet	Fans	Diameter		rpm	Air Throw	Noise Level	Motor Size	230v-1ph-50Hz			Ceiling mtd. W	Ceiling mtd. W
						Ins.	mm		m			Total Power Input W	F.L.C Amps Per Fan	S.C Amps Per Fan		
FTG3.5-5	1.15	1.05	1/2	1/2	1	9	230	1400	4.0	56	15	62	0.48	0.7	N/A	N/A
FTG3.5-5L	1.15	1.05	1/2	1/2	1	9	230	1400	4.0	56	15	62	0.48	0.7	900	2 x 425
FTG4.5	1.61	1.47	1/2	1/2	2	9	230	1400	4.0	59	15	124	0.96	1.4	N/A	N/A
FTG4.5L	1.61	1.47	1/2	1/2	2	9	230	1400	4.0	59	15	124	0.96	1.4	900	2 x 425
FTG5.5	1.89	1.72	1/2	1/2	2	9	230	1400	4.5	57	15	124	0.96	1.4	N/A	N/A
FTG5.5L	1.89	1.72	1/2	1/2	2	9	230	1400	4.5	57	15	124	0.96	1.4	1000	2 x 575

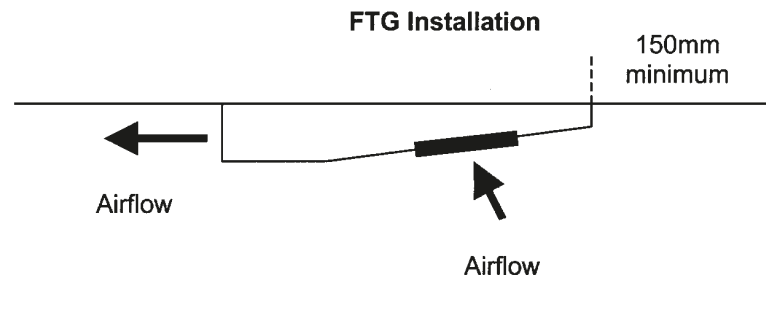

## FKS Range Without Defrost

Model	Capacity 8°K TD		Connections		FAN AND MOTOR SPECIFICATION									Electric Defrost		
	R404A/R507A	R134a	Inlet	Outlet	Fan /s	Diameter		rpm	Air Throw	Noise Level	Motor Size	230v-1ph-50Hz			Coil	Pan
						Ins.	mm		m			Total Power Input W	F.L.C Amps Per Fan	S.C Amps Per Fan		
FKS 10-4	1.67	1.52	1/2	1/2	1	12	305	1400	10	53	70	105	0.81	1.85	N/A	N/A
FKS 15-4	2.04	1.68	1/2	1/2	1	12	305	1400	10	53	70	105	0.81	1.85	N/A	N/A
FKS 20-4	2.66	2.42	1/2	5/8	1	12	310	1400	15	53	70	160	0.81	1.85	N/A	N/A
FKS 25-4	3.44	3.13	1/2	5/8	1	12	310	1400	14	53	70	160	0.81	1.85	N/A	N/A
FKS 35-4	5.16	4.70	1/2	7/8	2	12	310	1400	15	56	70	320	0.81	1.85	N/A	N/A
FKS 40-4	6.04	5.50	1/2	7/8	2	12	310	1400	13	56	70	320	0.81	1.85	N/A	N/A

## FKS Range With Defrost

Model	Capacity 8°K TD		Connections		FAN AND MOTOR SPECIFICATION									Electric Defrost		
	R404A/R507A	R134a	Inlet	Outlet	Fan /s	Diameter		rpm	Air Throw	Noise Level	Motor Size	230v-1ph-50Hz			Coil	Pan
						Ins.	mm		m			Total Power Input W	F.L.C Amps Per Fan	S.C Amps Per Fan		
FKS 20-6L	2.19	1.99	1/2	5/8	1	12	310	1400	15	53	70	160	0.81	1.85	0.650	0.650
FKS 25-6L	3.08	2.800	1/2	5/8	1	12	310	1400	14	53	70	160	0.81	1.85	0.790	0.790
FKS 35-6L	4.38	3.99	1/2	7/8	2	12	310	1400	15	56	70	320	0.81	1.85	1.210	1.210
FKS 40-6L	5.42	4.93	1/2	7/8	2	12	310	1400	13	56	70	320	0.81	1.85	1.210	1.210
FKS 45-6L	5.89	5.36	1/2	7/8	2	12	310	1400	14	56	70	320	0.81	1.85	1.425	1.425
FKS 55-6L	7.14	6.50	1/2	7/8	3	12	310	1400	15	58	70	480	0.81	1.85	2.135	4.270
FKS 70-6L	8.75	7.96	1/2	11/8	3	12	310	1400	14	58	70	480	0.81	1.85	2.135	4.270

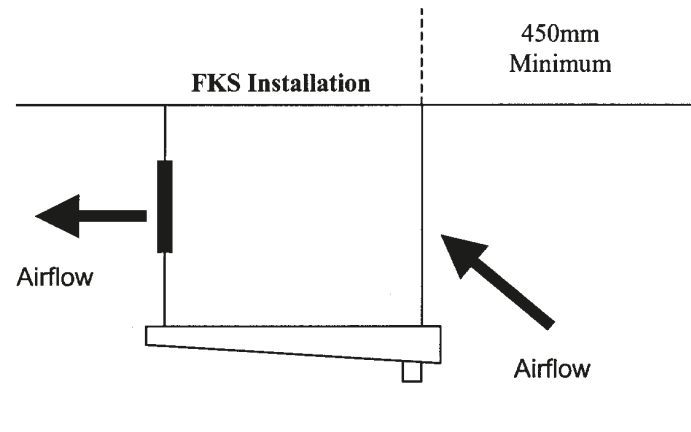

# Duet Installation Guide Notes

## 1. GENERAL

Installation should be carried out by competent persons adopting codes of good refrigeration practices as detailed in BS.EN 378-1:2000 Refrigerating Systems and Heat Pumps - Safety and environmental requirements. Particular care should be taken installing horizontal and vertical pipe runs incorporating correct bends, traps etc.

## 2. CONDENSING UNIT

Although the Condensing Unit is rated to operate in an ambient temperature up to 43°C it is still important to consider the location of the Unit during installation. Solar Gain from direct sunlight can raise the temperature inside the unit housing beyond the operating specification of the unit resulting in loss of performance and possible damage to equipment.

Equally protection from very low ambient conditions should be addressed. Basically consider protection components such as oil separators, head pressure control, additional solenoid valves, crankcase heaters etc for adverse operating conditions.

The Condensing Unit can be positioned at low level ensuring that it is raised off the ground and mounted on wall fixing brackets. There should be at least 600mm clearance in front of the unit to allow for adequate air to the condenser plus access for servicing through the top therefore at least 600mm clearance should be allowed.

## 3. PIPE RUNS

The nominal design pipe run for the system is 50 metres however care should be taken to consider any vertical rise where the condensing unit is situated above the coldroom. The introduction of "P" traps in the suction line to aid oil return to the compressor should be considered also the requirement of an oil separator, especially low temperature applications. Where the vertical rise is 5 metres and above the use of an oil separator should be considered, especially on low temperature applications, plus the position of the oil "P" trap and the size of the suction line to maximise oil return to the compressor.

## 4. EVAPORATORS / COOLERS

### FTG Range - Ceiling Mounted

These are used for small coldroom applications and are available for both high and low temperature conditions. The low temperature models have defrost heaters mounted under the coil block with access via the drain pan. It will not be necessary to allow space at the side of the Cooler for heater removal.

Positioning the Cooler should allow the discharged air from the finned face to circulate around the coldroom. The rear of the Cooler can be positioned close to the coldroom wall leaving sufficient space to remove the drain pan. If the opposing wall is less than 600mm from the finned face of the Cooler a curved air "deflector plate" should be used.

Fit the 1" BSP Drain Connector to the drain pan and connect the drain line to it.

### FKS Range

These ceiling mounted Coolers are designed for medium/large coldrooms for both high and low temperature applications.

The cooling air is discharged through the fan motors therefore it should be positioned within the coldroom allowing at least 450mm clearance between the rear finned face and the wall for air return to the Cooler. If the opposing wall is less than 1.5m from the fan motors a curved air "deflector plate" should be considered depending on model.

## 5. CONTROL PANEL

The Control panel is supplied with a main's isolator switch, function contactors, circuit breaker and a microprocessor temperature controller complete with 10m long temperature sensing probes. The air temperature sensing probe should be positioned in the return air to the finned evaporator coil and the defrost termination temperature sensing probes (when required) inserted at least 25mm into the finned coil at the top.

See separate wiring diagrams for the various Condensing Unit / Cooler.

# Duet Package Refrigeration System

**The Duet Package Refrigeration System Comprises of:**

**Air Cooled Condensing Unit (standard items)**

- Compressor
- Air cooled condenser
- Liquid receiver
- High/Low pressure switches
- Liquid line sight glass
- Filter Drier
- Liquid/Suction line shut off valves
- Crankcase heater (except DCU1-1H, DCU2-1H, DCU1-1L as option)
- Low ambient kit (only DCU5-3L, DCU6-3L others as option)
- Mounting Channels (DCU6-3H, DCU 7-3H, DCU 5-3L only)
- R404a refrigerant
- White unit cover

**Cooler**

- FTG Range with and without electric defrost heaters
- FKS Range with and without defrost heaters

**Control Panel**

- Microprocessor Controller c/w function indicators
- Ten metre sensing probes
- Component contactors
- Component circuit breakers

- Lockable isolator switch
- White enclosure
- Remote alarm contacts

**Ancillaries (supplied loose)**

- Expansion valve
- Liquid line solenoid valve
- Drain line heater (where applicable)
- Cooler fixing nylon bolts c/w nuts and washers

**Options**

- Wall brackets
- Oil separator (except DCU1-1H, DCU2-1H, DCU1-1L)
- Low ambient kit (except DCU5-3L, DCU6-3L this fitted as standard)
- 220-1-60hz in lieu of 230-1-50hz
- 220-3-60hz in lieu of 400-3-50hz

**Not included**

- Interconnecting pipework
- Pipe installation
- Mechanical fasteners (screws, pipe clamps etc.)
- Refrigerant
- Mains supply wiring

## Duet Specifications

Condensing unit Model	32°C Room Capacity (m³)	43°C Room Capacity (m³)	Duty @ 32°C	Cooler style	Cooler Type	Electrical Supply	Duty	Control Panel	Main Fuse (A)	Defrost Load (W)	Cooler Supply	Airthrow (m)
-----------------------	-------------------------	-------------------------	-------------	--------------	-------------	-------------------	------	---------------	---------------	------------------	---------------	--------------

**Gen. Purpose > +1°C (Evap -5°C)**

1-1H	0 > 8	0 > 3	1250	LP	FTG4-5	230-1-50	1620	DCPF	16	n/a	230-1-50	4
2-1H	8 > 11	3 > 6	1780	LP	FTG4-5	230-1-50	1620	DCPF	20	n/a	230-1-50	4
3-1H	11 > 19	6 > 10	2550	STD	FKS20-4	230-1-50	2660	DCPF	20	n/a	230-1-50	15
4-3H	19 > 33	10 > 18	3430	STD	FKS25-4	400-3-50	3440	DCPH	16	n/a	230-1-50	14
5-3H	33 > 44	18 > 24	4310	STD	FKS35-4	400-3-50	5160	DCPH	20	n/a	230-1-50	15
6-3H	44 > 70	24 > 44	5620	STD	FKS40-4	400-3-50	6040	DCPL	20	n/a	230-1-50	13

**Chill Storage -2°C/ +2°C (Evap -10°C)**

1-1M	0 > 6	0 > 2	980	LP	FTG3.5-5L	230-1-50	989	DCPG	20	900	230-1-50	4
2-1M	6 > 9	2 > 4	1400	LP	FTG4-5L	230-1-50	1385	DCPG	25	900	230-1-50	4
3-1M	9 > 19	4 > 7	2000	STD	FKS20-6L	230-1-50	1883	DCPG	25	1300	230-1-50	15
4-3M	19 > 29	7 > 14	2630	STD	FKS25-6L	400-3-50	2649	DCPN	25	1580	230-1-50	15
5-3M	29 > 42	14 > 22	3300	STD	FKS35-6L	400-3-50	3767	DCPN	25	2420	230-1-50	15
6-3M	42 > 69	22 > 37	4310	STD	FKS40-6L	400-3-50	4661	DCPN	25	2420	230-1-50	14

**Frozen Storage -18°C/ -21°C (Evap -28°C)**

1-1L	0 > 5	0 > 2	711	LP	FTG4-5L	230-1-50	1191	DCPG	25	900	230-1-50	4
2-1L	5 > 8	2 > 3	1092	LP	FTG5-5L	230-1-50	1399	DCPG	25	1000	230-1-50	5
3-3L	8 > 14	3 > 6	1627	STD	FKS20-6L	400-3-50	1621	DCPN	25	1300	230-1-50	15
4-3L	14 > 19	6 > 11	1806	STD	FKS25-6L	400-3-50	2279	DCPN	25	1580	230-1-50	15
5-3L	19 > 44	11 > 22	3749	STD	FKS40-6L	400-3-50	4011	DCPO	32	2420	230-1-50	14
6-3L	44 > 80	22 > 44	5403	STD	FKS55-6L	400-3-50	5284	DCPM	32	6405	400-3-50	16

**Expansion Valves and Solenoid Valves**

Duet Model R404A	Cooler Type	Valve	Body	Body Code	Orifice Number	Orifice Code	Solenoid Valve	Solenoid Valve Code	Drain Line Heater
------------------	-------------	-------	------	-----------	----------------	--------------	----------------	---------------------	-------------------

**Gen. Purpose > +1°C (Evap -5°C)**

1-1H	FTG4-5	TES 2-0.45	68Z3417	15450385	01 (68-2091)	15451103	EVR 6 (3/8)	15451215	00-554222
2-1H	FTG4-5	TES 2-0.45	68Z3417	15450385	01 (68-2091)	15451103	EVR 6 (3/8)	15451215	00-554222
3-3H	FKS20-4	TES2-0.6	68Z3417	15450385	02 (68-2092)	15451104	EVR 6 (3/8)	15451215	00-554222
4-3H	FKS25-4	TES2-1.2	68Z3417	15450385	03 (68-2093)	15451105	EVR 6 (3/8)	15451215	00-554222
5-3H	FKS35-4	TES2-1.2	68Z3417	15450385	03 (68-2093)	15451105	EVR 6 (3/8)	15451215	00-554222
6-3H	KS40-4	TES2-1.7	68Z3417	15450385	04 (68-2094)	15451106	EVR 6 (3/8)	15451215	00-554222

**Note: The External equaliser line is not fitted to the coolers.**

**External equaliser to be fitted by the installation engineer within 200mm from the suction outlet on the cooler.**

**Chill Storage -2°C/ +2°C (Evap -10°C)**

1-1M	FTG3.5-5L	TES 2-0.45	68Z3417	15450385	01 (68-2091)	15451103	EVR 6 (3/8)	15451215	00-554222
2-1M	FTG4-5L	TES 2-0.45	68Z3417	15450385	01 (68-2091)	15451103	EVR 6 (3/8)	15451215	00-554222
3-1M	FKS20-6L	TES2-0.6	68Z3417	15450385	02 (68-2092)	15451104	EVR 6 (3/8)	15451215	00-554222
4-3M	FKS25-6L	TES2-0.6	68Z3417	15450385	02 (68-2092)	15451104	EVR 6 (3/8)	15451215	00-554222
5-3M	FKS35-6L	TES2-1.2	68Z3417	15450385	03 (68-2093)	15451105	EVR 6 (3/8)	15451215	00-554222
6-3M	FKS40-6L	TES2-1.2	68Z3417	15450385	03 (68-2093)	15451105	EVR 6 (3/8)	15451215	00-554222

**Note: The External equaliser line is not fitted to the coolers.**

**External equaliser to be fitted by the installation engineer within 200mm from the suction outlet on the cooler.**

**Frozen Storage -18°C/ -21°C (Evap -28°C)**

1-1L	FTG4-5L	TES 2-0.45	68Z3417	15450385	01 (68-2091)	15451103	EVR 6 (3/8)	15451215	00-554222
2-1L	FTG5-5L	TES 2-0.45	68Z3417	15450385	01 (68-2092)	15451104	EVR 6 (3/8)	15451215	00-554222
3-3L	FKS20-6L	TES2-0.6	68Z3417	15450385	02 (68-2092)	15451104	EVR 6 (3/8)	15451215	00-554222
4-3L	FKS25-6L	TES2-1.2	68Z3417	15450385	03 (68-2093)	15451105	EVR 6 (3/8)	15451215	00-554222
5-3L	FKS40-6L	TES2-1.7	68Z3417	15450385	04 (68-2094)	15451106	EVR 6 (3/8)	15451215	00-554222
6-3L	FKS55-6L	TES2-2.2	68Z3430	15450386	05 (68-2095)	15451107	EVR 10 (1/2)	15451219	00-554222

**Note: The External equaliser line is not fitted to the coolers.**

**External equaliser to be fitted by the installation engineer within 200mm from the suction outlet on the cooler.**

# FKS Cooler Dimensions

Model	A	B	C	D
FKS 10	720	430	467	417
FKS 15	720	430	467	417
FKS 20	770	480	467	417
FKS 25	870	580	542	492
FKS 35	1170	880	467	417
FKS 40	1170	880	542	492
FKS 45	1320	1030	542	492
FKS 55	1820	1530	467	417
FKS 70	1820	1530	542	492

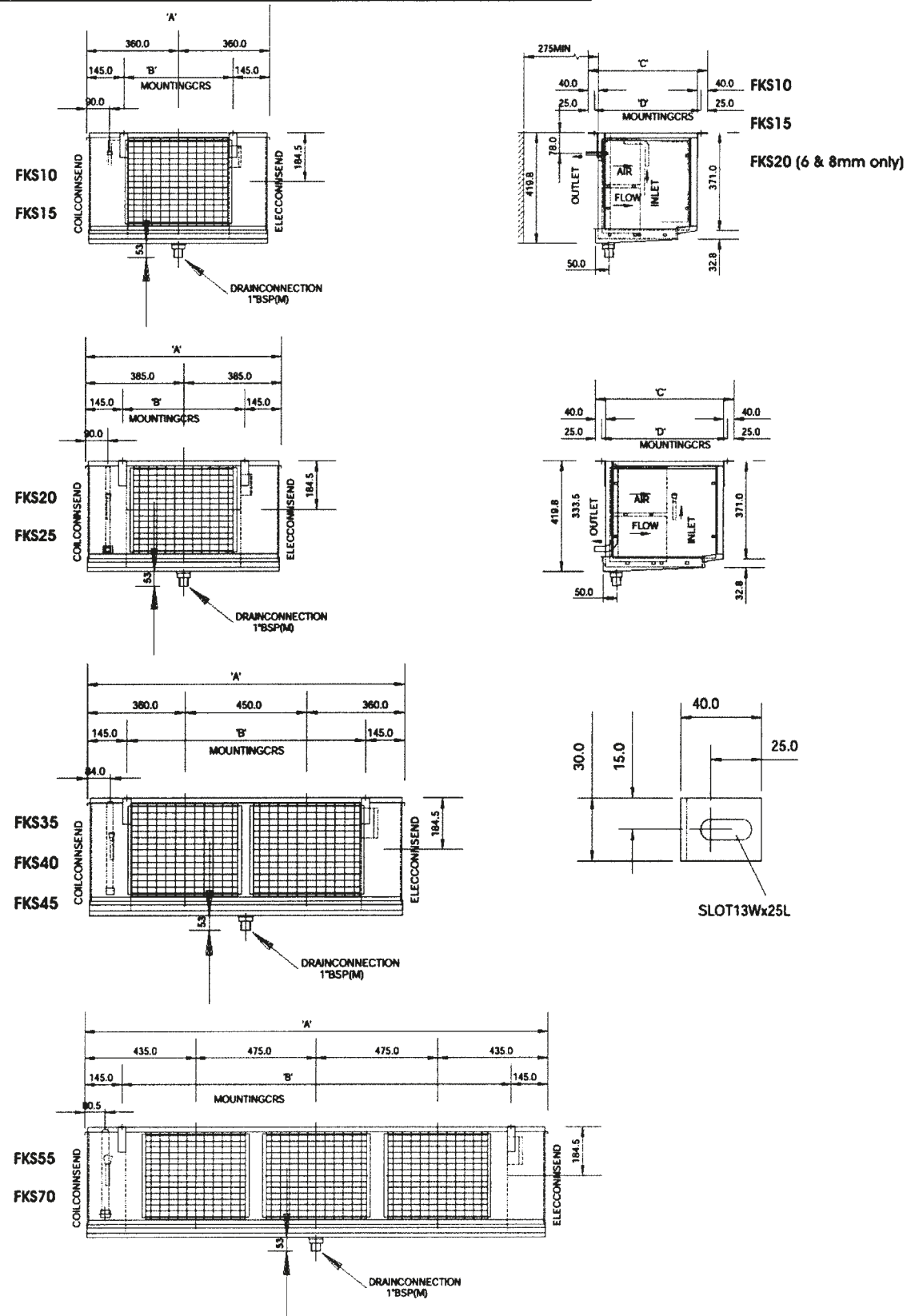

# DUET 'C', 'F', 'M', 'L' AND 'IC' SERIES

Par. No.	1	2	3	4	5	6	7	8	9	10	11	12	13	14	15	16	17	18	19	20	21	22	23	24	25	26
	Cooler minimum set	Cooler maximum set	Cooler hysteresis	Cooler min. off time	Cooler min. on time	Cooler duty cycle	Cooler re-start	Defrost repetition time	Defrost limit temperature	Defrost time out	Dripping time	Display in defrost	Defrost type	Defrost optimisation	Evaporator fan control	Fan re-start after defrost	Ventilation in defrost	Low alarm threshold	High alarm threshold	Temperature alarm delay	Alarm probe selection	Thermostat probe offset	Evaporator probe offset	Displayed probe offset	Thermal mass simulation	Peripheral number
Units	Deg	Deg	Deg	Min	Min	%	Sec	Hrs	Deg	Min	Min	Min	Flag	Flag	Min	Deg	Flag	Deg	Deg	Min	Flag	Deg	Deg	Flag	Flag	01
Mnemonic	SPL	SPh	hYS	coF	con	cdc	crS	drE	dLI	dto	drP	diS	dtY	doP	Fct	FrS	Fid	ALo	Ahi	AdL	Ain	oS1	oS2	oS3	SIM	Adr
Min. Limit	-50	SPL	01	00	00	00	00	01	01	00	00	-01	FAn ELE	con	-01	-50	* 01	-50	SPh	-01	01	-20	-20	-20	00	1
Max. Limit	150	150	20	10	10	10	120	99	70	120	10	30	GAS	Acc	10	50	02	SPL	50	120	03	20	20	20	200	255

\*00 = OFF  
01 = Te < FrS  
02 = Always ON

C	0	8	02	00	00	06	00	06	20	15	05	05	ELE	con	-1	01	00	-3	8	60	01	00	00	00	00	01
F	-5	8	02	00	00	06	00	06	20	15	05	05	ELE	con	-1	01	00	-10	8	60	01	00	00	00	00	01
M	-3	8	02	00	00	06	00	06	20	15	05	05	ELE	con	-1	01	00	-8	8	60	01	00	00	00	00	01
L	-23	-15	03	00	00	06	00	03	30	30	05	05	ELE	con	-1	5	00	-25	-10	60	01	00	00	00	00	01
IC	-28	-18	03	00	00	06	00	03	30	30	05	05	ELE	con	-1	5	00	-30	-15	60	01	00	00	00	00	01

# Electrical System Description

## CONTROL PANEL/WIRING DIAGRAMS

The Duets are to be wired in accordance with the latest revision of the respective wiring diagram:

SEE DETAIL FOR REMOTE ALARM CONNECTION

Duet Model	Control Panel Code	Wiring Schematic	Wiring Diagram No	Condenser Wiring Diagram No.	Remote alarm Control panel Terminal Numbers
1-1H, 2-1H, 3-1H.	DCPF	Fig 2	00-838099-00	-----	9,10,11.
4-3, 5-3H.	DCPH	Fig 2	00-838101-00-page 1	00-838101-00-page 2	11,12,13.
6-3H.	DCPL	Fig 2	00-838102-00-page 1	00-838102-00-page 2	11,12,13.
1-1M, 2-1M, 3-1M, 1-1L, 2-1L.	DCPG	Fig 2	00-838100-00	-----	13,14.
4-3M, 5-3M, 6-3M, 3-3L, 4-3L.	DCPN	Fig 1	00-838359-00	00-838360-00 or 00-838361-00	17,18.
5-3L	DCPO	Fig 1	00-838362-00	00-838363-00	17,18.
6-3L	DCPM	Fig 3	00-838106-00-page 1	00-838106-00-page 2	17,18.



# Duet Package Wiring Schematic

Fig 1.

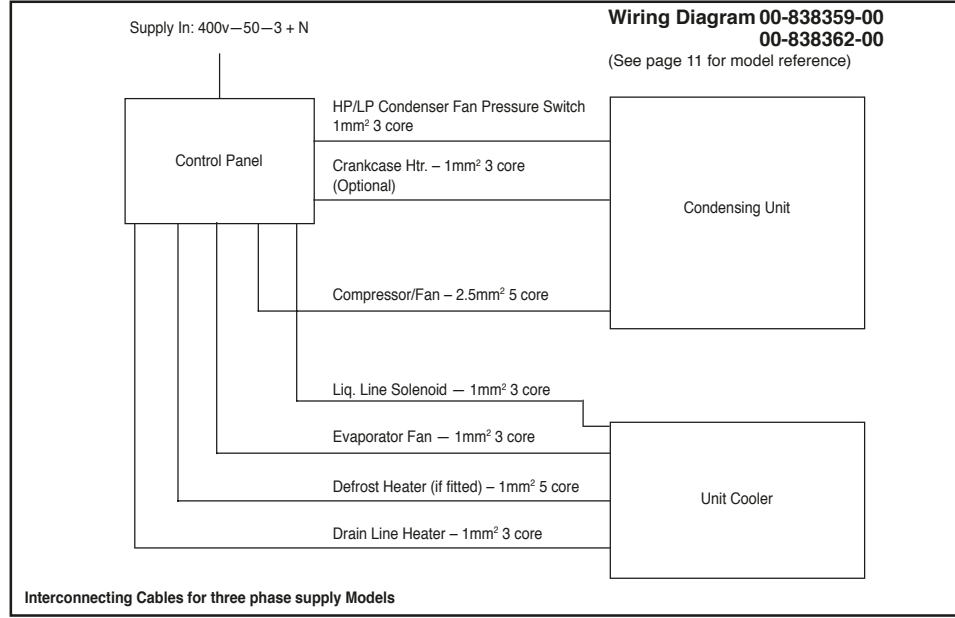

Fig 2.

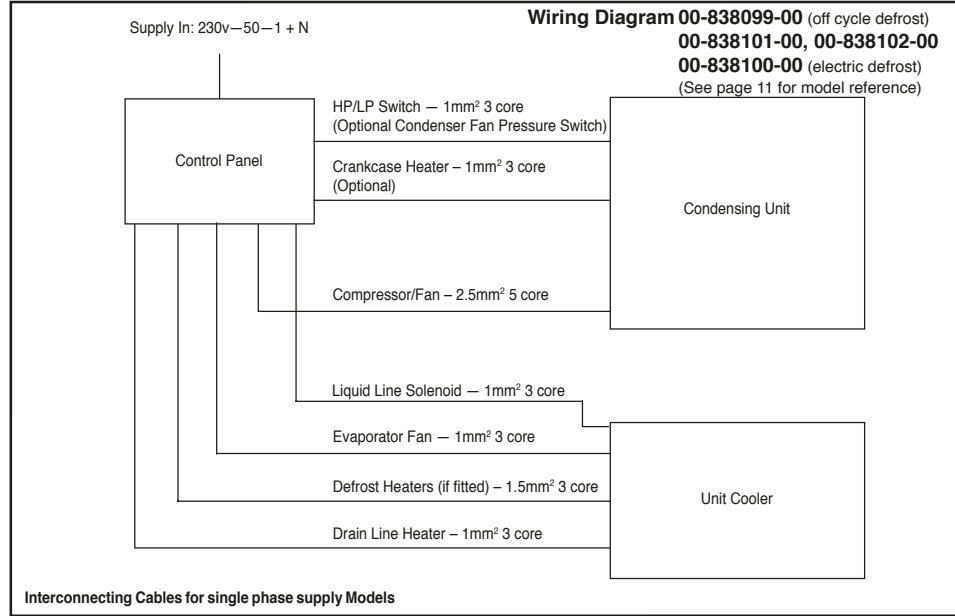
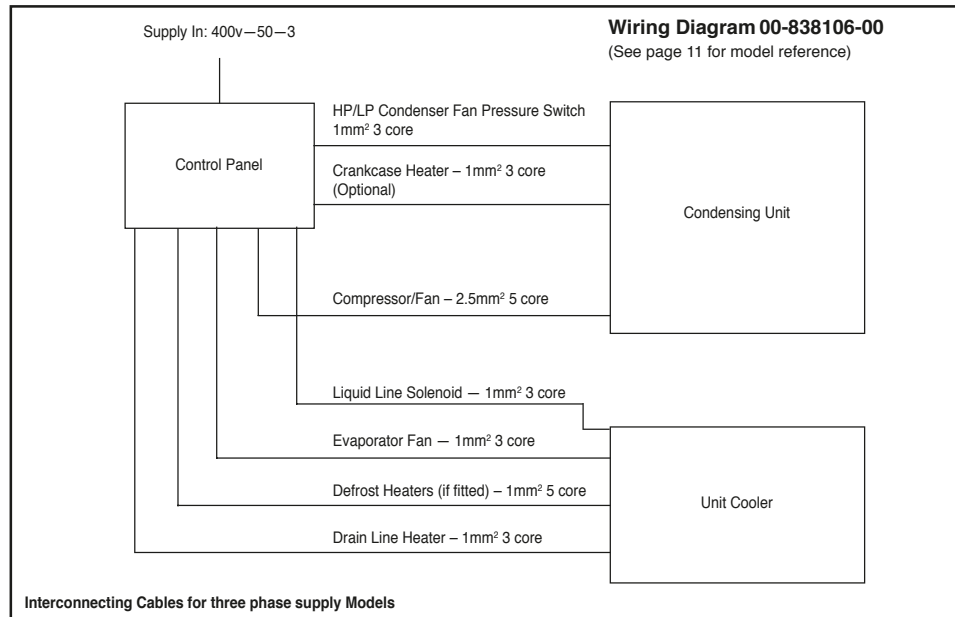

Fig 3.



## CONDENSING UNIT TECHNICAL DATA

Model	Nom hp	Refrigerant	Gas Charge	Receiver** Capacity lts	HP Setting Bar	LP Setting Bar	Electrical supply		*Abs Kw	*Max *Nom Amps	Max Run Amps	Start Amps	Cond Fuse Rating	Air Fan Motor x mm	Volume m <sup>3</sup> /hr	***Unit Absorbed Watts	Net Noise Level dBa	kgs Weight	Dimensions Ht x w x d mm	Liquid Line mm	Suction Line mm	
							Volts	Phase														Hz
DCU1-1H	0.5	R 404a	1.00	1.6	28	0.2	230	1	50	0.5	3.2	6.3	19	13	1 x 250	750	1 x 90	59	39	368 x 660 x 330	10	12
DCU2-1H	0.75	R 404a	1.00	1.6	28	0.2	230	1	50	0.7	3.7	7.8	31	20	1 x 250	750	1 x 90	60	43	368 x 660 x 330	10	16
DCU3-1H	1	R 404a	1.60	2.5	28	0.2	230	1	50	1.1	5.1	11.3	32	20	1 x 300	1400	1 x 90	60	61	458 x 880 x 400	10	16
DCU4-3H	1.8	R 404a	2.00	2.5	28	0.2	400	3	50	1.7	3.6	6.6	18	16	1 x 330	1500	1 x 120	62	62	458 x 880 x 400	10	16
DCU5-3H	2.3	R 404a	2.00	2.5	28	0.2	400	3	50	2.1	4.4	8.1	25	20	1 x 330	1500	1 x 120	63	64	458 x 880 x 400	10	22
DCU6-3H	3	R 404a	6.00	6.5	28	0.2	400	3	50	3.2	6.2	9.7	27	20	1 x 400	3100	1 x 160	64	102	595 x 1075 x 532	10	22
DCU1-1L	0.75	R 404a	1.50	1.6	28	0.2	230	1	50	0.8	3.8	7	28	16	1 x 250	750	1 x 90	60	46	368 x 660 x 330	10	16
DCU2-1L	1.8	R 404a	1.60	2.5	28	0.2	230	1	50	1.4	8.6	16	40	20	1 x 300	1400	1 x 90	60	60	458 x 880 x 400	10	22
DCU3-3L	2.3	R 404a	1.60	2.5	28	0.2	400	3	50	1.8	4.5	6.2	25	16	1 x 300	1400	1 x 90	61	65	458 x 880 x 400	10	22
DCU4-3L	3	R 404a	2.00	2.5	28	0.2	400	3	50	1.8	4.8	5.8	30	20	1 x 350	1500	1 x 120	61	73	458 x 880 x 400	10	22
DCU5-3L	4	R 404a	6.00	6.5	28	0.2	400	3	50	3.8	7.9	12.7	71	25	1 x 400	3100	1 x 160	68	120	595 x 1075 x 532	10	28
DCU6-3L	7.5	R 404a	10.00	12	28	0.2	400	3	50	5.8	12	24.8	80	25	1 x 450	3100	1 x 160	72	187	654 x 1575 x 642	12	35

**NOTE:**  
\* Based on 40°C condensing temperature.  
\*\* Based on 80% liquid capacity at 40°C condensing temperature.  
\*\*\* Based on 3 metres from front of unit, 1.5 metres from floor level.

# Control Panel

The control panel contains a microprocessor temperature controller indicator automatically controlling the required process to maintain the correct storage temperature within the coldroom and initiate and control defrost and evaporator fan functions. The controllers are pre-set prior to leaving the factory but should it be necessary to make an adjustment the following procedures should be followed.

## MICROPROCESSOR CONTROLS

### Duet 'H' Series

All controller parameters are factory set for optimum storage conditions. The parameters should only be adjusted by persons familiar with the unit operation and controller functions. Certain parameters however may be adjusted within limits, to suit certain storage needs.

## DUET HIGH TEMPERATURE UNITS WITH LDU 15 CONTROLLER - 00-555357

### Temperature Controller

When the controller is switched on a single line appears on the display for 3 seconds to indicate the autotest period. After this period the air temperature measured by the T1 probe is displayed.

It is strongly advised that before adjusting any Service Parameters a thorough understanding of the following instructions should be obtained.

### LDU 15 CONTROLLER

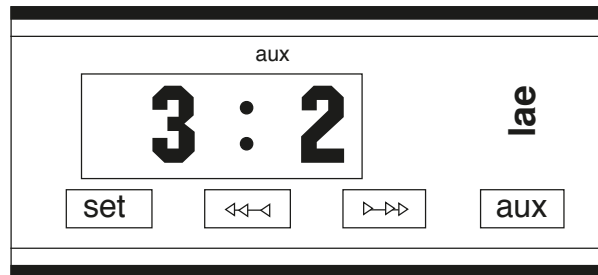

Check temperature set point.

Check set point by pressing the "set" button

To increase set point press "set" +

To decrease set point press "set" +

Factory Temperature Set Point +3°C.

Exit from set up occurs after 10 seconds if no button is pressed.

### Controller Set Up.

The parameters are accessed by pressing the following keys in succession + "set" + and keeping them pressed for 3 seconds.

Access to the parameters has been achieved with the first parameter SCL being displayed.

To pass from one parameter to the next press either the or key

To display the value press. "set"

To change the value press "set" + to increase, or "set" + to decrease.

Exit from set up by pressing "aux" or is automatic after 30 seconds if no buttons are pressed.

## MICROPROCESSOR CONTROLS

### Duet 'M' and 'L' Series

All controller parameters are factory set for optimum storage conditions. The parameters should only be adjusted by persons familiar with the unit operation and controller functions. Certain parameters however may be adjusted within limits, to suit certain storage needs.



**Check Set Point** — Low point of temperature band

Press button 1 ()

### Increase Set Point

Press and hold button 1 ()

Press button 3 () until required temperature is displayed

### Decrease set point

Press and hold button 1 ()

Press button 4 () until required temperature is displayed

### Manual Defrost

Press and hold button 2 ()

Press button 4 () a timed defrost will follow

### Indicators

LED 5 Compressor on ()

LED 6 Evaporator fan on ()

LED 7 Defrost on ()

PF1 or PF2: Indicates a probe failure — call engineer

### Adjustment Parameters

Freezer: Set Point -21°C

Meat: Set Point -2°C

## Thermostat Function

**SPL** Min set point (°C)  
Maximum allowable low alarm setting (°C)

**SPh** Maximum set point (°C)  
Maximum allowable high alarm setting (°C)

**hyS** Temperature hysteresis (°K)

**coF** Compressor minimum off time (mins)

**con** Compressor minimum on time (mins)

**cdc** Cooler duty cycle. Compressor on duration during a ten minute cycle e.g. **cdc** = 04, 4 min on time, 6 min off time (active only under probe fault conditions, **PF1**)

**crS** Compressor start delay (secs)

## Defrost Function

**drE** Time between defrosts (hrs)

**dLi** Defrost termination temperature (°C)

**dto** Defrost termination time (mins). Unused if set to zero

**drP** Drain down time (mins)

**diS** Display during defrost

**00** = Temperature display  
— **01** = **DEF** is displayed during defrost and until air temperature falls below the value setpoint — hysteresis.

**1.30 (mins)** = **dEF** is displayed during defrost and until the set time has elapsed after defrosting or until air temperature falls below the value setpoint + hysteresis.

**dtY** Defrost type

**FAn** = Off cycle defrost

**ELE** = Electric heater defrost

**GAS** = Hot gas defrost

**doP** Defrost optimisation

**con** = At regular intervals of **drE** (hrs)

**Acc** = Defrost timer only runs while evaporator temperature is below 0°C, defrosting occurs when **drE** time has elapsed e.g. if compressor cycle time is 5 min run and 5 min stop and **drE** = 4, defrosting will take place every 8 hours approx

## Evaporator Fan Control

**Fct** Evaporator fan control during cooling

— **01** = Continuous operation

**00** = Cycle on/off with compressor

**1.10 (mins)** = Start with compressor, set time delay stop after compressor

**Frs** Fan delay temperature following defrost (°C)

**Fid** Evaporator fan operation during defrost

**00** = off until fan delay temperature **FrS** (°C) is reached

**01** = On while evaporator temperature is below value **FrS** (°C)

**02** = On during defrost

## Alarm Function

**ALo** Low temperature alarm setting (°C)

**Ahi** High temperature alarm setting (°C)

**AdL** Alarm delay (min)

**00** = Instantaneous audible alarm

**01.120** = Duration of delay (min)

— **01** = Alarm is disabled

**Ain** Determines which probe is monitored for alarm functions

**1** = Air probe (probe 1)

**2** = Evaporator probe (probe 2)

**3** = Food probe (probe 3)

## Thermal Mass Simulation

**oS1** Air probe offset (°K)

**oS2** Evaporator probe offset (°K)

**oS3** Food probe offset (°K) — where fitted

**SiM** Controls the thermal mass volume simulated by the controller and displayed on the fascia. The greater the value the greater the resulting display slow down. The controlling function remains to operate directly on air temperature.

**00** = Instantaneous air temperature display

**01.200** = Thermal mass simulation

**Adr** Controller peripheral number — only used where controllers are networked

## Display

When the unit is switched on the display shows “- -” for a period of five seconds, during which the controller performs a self check. The display then shows the air temperature measured by probe 1.

The coil temperature, measured by probe 2 may be viewed by pressing [ ].

Access to the control parameters is achieved by pressing in sequence [ ] + [ ] + [ ] and holding in keys for a period of 4 seconds.

It is possible to scroll through the parameters by pressing - [ ]

or [ ].

The value of a selected parameter is checked by pressing - [ ] and may be altered by pressing at the same time [ ] + [ ] or [ ].

Exit from setup occurs after 10 seconds if no key is pressed.

If an alarm condition is entered the alarm buzzer will sound and ‘ALM’ will flash on the display. The alarm may be acknowledge by pressing any key causing the buzzer to cease and the display will alternate between ‘ALM’ and air temperature while the alarm condition persists. The alarm will also re-sound every 30 minutes while an alarm condition persists.

# Controller Parameter Settings

## DUET ‘HV’ AND ‘GP’ SERIES

Display	Parameter Default Values	LDU151E-B Used in Panels F,H,L.	Duet High Temp
SCL	Readout Scale	2°C	2°C
SPL	Minimum Temperature Set Point	05	0
SPH	Maximum Temperature Set Point	01	8
SP	Effective Temperature Set Point	03	2
HYS	Hysteresis	3	+3
CRT	Compressor Rest Time (minutes)	10	2
CDC	Compressor Regulation with T1 Fail	20	7
DFR	Defrosting Frequency (/24 hours)	4	4
DTO	Defrosting Duration (minutes)	20	15
DDY	Defrost Display Control	1	1
ATL	Low Alarm Differential	-5	-5
ATH	High Alarm Differential	5	10
ATD	Temperature Alarm Delay (minutes)	60	90
ACC	Condenser Clean Interval	05	0
OAU	Auxiliary Output Mode of Operation	30	ALR
BAU	Auxiliary Button Mode of Operation	05	NON
OS1	T1 Offset	00	00
SIM	Display Slowdown	00	00
ADR	Address	01	01

□

## ALARMS AND WARNINGS

HI	High Temperature Alarm
LO	Low Temperature Alarm
E1	T1 Probe Failure
DF	Defrosting in Progress
CLN	Condenser

## LDU 151E-BG Electrical Connections

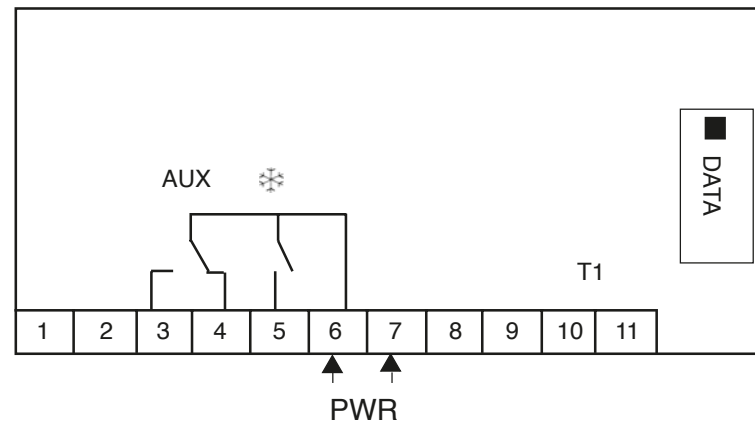

# FTG Cooler Dimensions

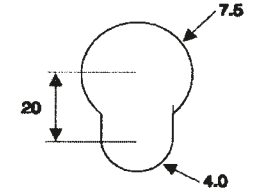
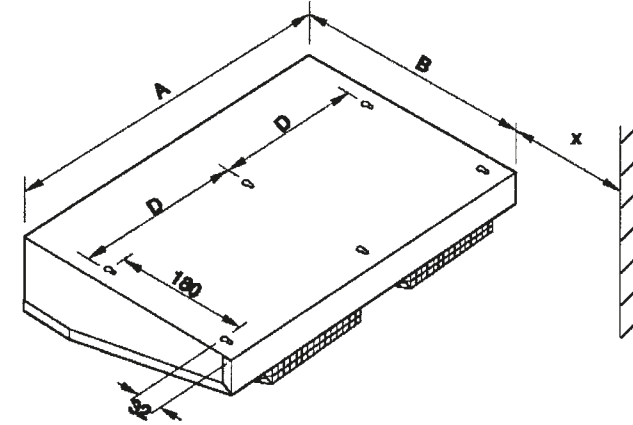

Model	mm					
	Fans	A	B	C	D	X min
FTG3.5-5	1	865	375	180	793 (x4)	120
FTG4-5	2	865	375	180	793 (x4)	120
FTG 5-5	2	1120	375	180	524 (6)	120

## LIQUID AND SUCTION LINE PIPE SIZE

Model	32°C Ambient					
	Liquid Line Pipe Size		Suction Line Pipe Size			
	20m	50m	Horizontal		Vertical	
Duet	20m	50m	20m	(V)	50m	(V)
1-1 H/M	3/8"	3/8"	1/2"	1/2"	5/8"	1/2"
2-1 H/M	3/8"	3/8"	5/8"	1/2"	5/8"	1/2"
3-1 H/M	3/8"	3/8"	5/8"	1/2"	5/8"	1/2"
4-3 H/M	3/8"	3/8"	7/8"	3/4"	7/8"	3/4"
5-3 H/M	3/8"	3/8"	7/8"	3/4"	11/8"	7/8"
6-3 H/M	3/8"	3/8"	11/8"	7/8"	11/8"	7/8"

1-1 L	3/8"	3/8"	5/8"	1/2"	3/4"	5/8"
2-1 L	3/8"	3/8"	3/4"	5/8"	7/8"	3/4"
3-3 L	3/8"	3/8"	7/8"	3/4"	7/8"	3/4"
4-3 L	3/8"	3/8"	7/8"	3/4"	11/8"	7/8"
5-3 L	3/8"	3/8"	11/8"	7/8"	13/8"	11/8"
6-3 L	1/2"	1/2"	13/8"	11/8"	13/8"	11/8"

Model	43°C Ambient					
	Liquid Line Pipe Size		Suction Line Pipe Size			
	20m	50m	Horizontal		Vertical	
Duet	20m	50m	20m	(V)	50m	(V)
1-1 H/M	3/8"	3/8"	1/2"	1/2"	5/8"	1/2"
2-1 H/M	3/8"	3/8"	5/8"	1/2"	5/8"	1/2"
3-1 H/M	3/8"	3/8"	5/8"	1/2"	5/8"	1/2"
4-3 H/M	3/8"	3/8"	7/8"	3/4"	7/8"	3/4"
5-3 H/M	3/8"	3/8"	7/8"	3/4"	11/8"	7/8"
6-3 H/M	3/8"	3/8"	11/8"	7/8"	11/8"	7/8"

1-1 L	3/8"	3/8"	5/8"	1/2"	3/4"	5/8"
2-1 L	3/8"	3/8"	3/4"	5/8"	7/8"	3/4"
3-3 L	3/8"	3/8"	7/8"	3/4"	7/8"	3/4"
4-3 L	3/8"	3/8"	7/8"	3/4"	11/8"	7/8"
5-3 L	3/8"	3/8"	11/8"	7/8"	13/8"	11/8"
6-3 L	1/2"	1/2"	13/8"	11/8"	13/8"	11/8"

Note: These are guidelines only. Exact pipe sizing to be carried out for each application.

"H" models include HV and GP range  
 "M" models include C, F and M range  
 "L" models

The exact pipe size should be determined by application.

Recommended maximum vertical change 5 metres. The suction lines have been selected to achieve a pressure drop of 2psi or less whilst maintaining refrigerant velocity in the horizontal plane of 3.5m/s (700ft/min) and in the vertical plane of 7.0m/s (1500ft/min) to achieve oil return.